

p-ISSN 2339-1286
e-ISSN 2089-4392

Jurnal Pendidikan IPA Indonesia

Indonesian Journal of Science Education



Science Education Studies Program, Faculty of Mathematics and Natural Sciences,
Semarang State University collaborate with Perkumpulan Pendidik IPA Indonesia (PPII) /
Indonesian Society for Science Educators

JPII	Volume 4	Number 1	Pages 1 - 100	Semarang April 2015	p-ISSN 2339-1286 e-ISSN 2089-4392
-------------	----------	----------	------------------	------------------------	--------------------------------------

Scopus Citation Analysis
Contact Us

User

Username

Password

Remember me

COLLABORATE WITH



Editorial Advisory Regional America

- » Prof. San Ping Jiang, (Scopus ID: 7404452780) Curtin University, Perth, Australia

Editorial Advisory Regional South Asia

- » Dr. Imran Parvez, Hajee Mohammad Danesh Science & Technology University, Bangladesh

Editorial Advisory Regional Southeast Asia

- » Prof. Dr. Melor Yunus, [Scopus ID 36521977800] PERMATApintar National Gifted Centre, Universiti Kebangsaan Malaysia, Bangi, Malaysia
- » Prof. Dr. Poonsuk Prasertsan, (Scopus ID: 6603488014) Prince of Songkla University, Department of Industrial Biotechnology, Halyai, Thailand
- » Prof. Dr. Lilia Halim, (Scopus ID: 14624924300) Faculty of Education, National University of Malaysia, Malaysia

Editorial Board

Home About Login Register Search Archive Announcements



Editorial Team

Editor-in-Chief

- » Dr. Pirmin, (Scopus ID: 57193713988) Science Education, Faculty of Mathematics and Natural Sciences, Universitas Negeri Semarang, Indonesia

Editorial Advisory Regional Europe

- » Prof. Dr. Hans-Dieter Barke, (Scopus ID: 8061598100) Universitat Hannover, Hannover, Germany

Editorial Advisory Regional Africa

Editorial Policies
Focus & Scope
Ethics Statement
Abstracting/Indexing
Editorial Board
Peer Reviewer

journal.unnes.ac.id/ju/index.php/pi/about/editorialTeam

EDITORIAL BOARD

» Prof. Dr. Edy Cahyono, [Scopus ID: 56272286900] Chemistry Education, Faculty of Mathematics and Natural Sciences, Universitas Negeri Semarang, Indonesia

» Prof. Dr. Sutikno Sutikno, [Scopus ID: 18937265100] Physic, Faculty of Mathematics and Natural Sciences, Universitas Negeri Semarang, Indonesia

» Prof. Dr. Anna Permanasari, [Scopus ID: 57190941776] Chemistry, Faculty of Mathematics and Natural Sciences, Universitas Pendidikan Indonesia, Indonesia, Indonesia

» Prof. Dr. Sudharjo P. Hadi, [Scopus ID: 16068457500] Environmental Science, Universitas Diponegoro, Indonesia

» Prof. Dr. Mohamad Amin, [Scopus ID: 57188809077] Environmental Science, Faculty of Mathematics and Natural Sciences, Universitas Negeri Malang, Indonesia

» Dr. Wahono Widodo, [Scopus ID: 57191165275] Universitas Negeri Surabaya

» Prof. Dr. rer. nat. Sajidan Sajidan, [Scopus ID: 24484557700] Universitas Sebelas Maret, Indonesia

» Dr. Sigit Septono, (ORCID iD 0000-0001-8169-4814) Biology Education, Faculty of Mathematics and Natural Sciences, Universitas Negeri Semarang, Indonesia

» Prof. Dr. Sudarmin Sudarmin, (Scopus ID: 57193226009) Science Education, Faculty of Mathematics and Natural Sciences, Universitas Negeri Semarang, Indonesia

» Prof. Dr. Widha Sunarno, (Scopus ID: 57190938651) Physics Education, Faculty of Mathematics and Natural Sciences, Universitas Sebelas Maret, Indonesia

Readers

BR	ID	377,553	SG	1,129
US	25,909	JK	KR	1,036
FR	5,788	CN	1,020	
IN	1,999	RU	632	
TH	1,862	TR	532	
PK	1,422	CA	474	
IR	1,456	ZA	450	
GB	1,363	HK	443	
JP	1,297	DE	354	
AU	1,177	GR	340	

Pageviews: 1,379,629
Rags Collected: 147

Jurnal Pendidikan IPA Indonesia

Q3 Education

SJR 2018

0.25 best quartile

powered by scimagix.com

journal.unnes.ac.id/ju/index.php/pi/about/editorialTeam

» Prof. Dr. Sudarmin Sudarmin, (Scopus ID: 57193226009) Science Education, Faculty of Mathematics and Natural Sciences, Universitas Negeri Semarang, Indonesia

» Prof. Dr. Widha Sunarno, (Scopus ID: 57190938651) Physics Education, Faculty of Mathematics and Natural Sciences, Universitas Sebelas Maret, Indonesia

» Prof. Dr. Sri Ngabekti, [Scopus ID: 57195053485] Biology, Faculty of Mathematics and Natural Sciences, Universitas Negeri Semarang, Indonesia

Administration

» Ani Widayatrioko, [Scopus ID: 57190682690] Science Education, Faculty of Mathematics and Natural Sciences, Universitas Negeri Semarang, Indonesia

» Novi Ratna Dewi, [h-index 2] Science Education Department, Mathematics and Natural Science Faculty, D5 building first floor, Semarang State University, Central Java, Indonesia 50225, Indonesia

» Stephanie Diah Pamelasan, [Scopus ID: 57194033052] Science Education, Faculty of Mathematics and Natural Sciences, Universitas Negeri Semarang, Indonesia

» Erna Noor Savitri, [SCOPUS ID: 57196097401] Science Education, Faculty of Mathematics and Natural Sciences, Universitas Negeri Semarang, Indonesia

» Andin Vita Amalia, [h-index 2] Science Education, Faculty of Mathematics and Natural Sciences, Universitas Negeri Semarang, Indonesia

#24077 Summary

Summary | Review | Editing

Submission

Authors M Haviz, Lufri Lufri, Ika Metiza Mars

Title Assessing Prospective Biology Teachers' (PBTs) Perception on Thinking as 21st Century Skill, A Case Study at Islamic University

Original file [24077-59604-1-SM.docx](#) 2020-04-17

Supp. files [24077-59607-1-SP.pdf](#) 2020-04-17 [Add a Supplementary File](#)

Submitter M Haviz

Date submitted April 17, 2020 - 06:25 AM

Section Articles

Editor Erna Noor Savitri

Status

User

#24077 Summary

Summary | Review | Editing

Submission

Authors M Haviz, Lufri Lufri, Ika Metiza Mars

Title Assessing Prospective Biology Teachers' (PBTs) Perception on Thinking as 21st Century Skill, A Case Study at Islamic University

Original file [24077-59604-1-SM.docx](#) 2020-04-17

Supp. files [24077-59607-1-SP.pdf](#) 2020-04-17 [Add a Supplementary File](#)

Submitter M Haviz

Date submitted April 17, 2020 - 06:25 AM

Section Articles

Editor Erna Noor Savitri

Status

User



jpii@mail.unnes.ac.id



1

Article Submission Inbox x

**Jurnal Pendidikan IPA Indonesia** <jpii@mail.unnes.ac.id>

to me

Dear Author,

We are wishing you are in good health. We would like to process your article entitled "Assessing P Case Study Islamic University in Indonesia " to be processed for further issue. Please sub step.

We would like to hear from you soon.

Thank you very much.

Sincerely,

JPII Team

Jurnal Pendidikan IPA Indonesia

Nationally Accredited based on the Decree of the Minister of Research, Technology and Higher Education, N

Jurnal Pendidikan IPA Indonesia (Indonesian Journal of Science Education) [p-ISSN 2339-1286 | e-ISSN 2089 education in primary education, secondary education and higher education. This journal in collaborate with *Perkum*

This journal has been indexed in [Google Scholar](#), [DOAJ](#), [EBSCO](#), [SCOPUS](#)

[Official Contact](#)



No r
of
Start
n



Update: Manuscript Review Inbox ×



Jurnal Pendidikan IPA Indonesia <jpii@mail.unnes.ac.id>

to me

Dear Authors,

We are pleased to inform that the reviewer has uploaded the review results of your article.

Please check your OJS account for the newest review results.

We are looking forward to your revision **not later** than May 5, 2020.

Thank you.

Best regards,

JPII Team

Jurnal Pendidikan IPA Indonesia

Nationally Accredited based on the Decree of the Minister of Research, Technology and Higher Education, N

Jurnal Pendidikan IPA Indonesia (Indonesian Journal of Science Education) [p-ISSN 2339-1286 | e-ISSN 2085-
education in primary education, secondary education and higher education. This journal in collaborate with *Perkum*

This journal has been indexed in [Google Scholar](#), [DOAJ](#), [EBSCO](#), [SCOPUS](#)

No r
ct
Start
n



jpii@mail.unnes.ac.id



Manuscript Update Inbox x

1



Jurnal Pendidikan IPA Indonesia

to me

Dear Authors,

We are pleased to inform that the reviewer has uploaded the review results of your article. Please check your OJS account for the newest review results. We are looking forward to your revision **not later** than May 27, 2020. Thank you.

Best regards,
JPII Team

Jurnal Pendidikan IPA Indonesia

Nationally Accredited based on the Decree of the Minister of Research, Technology and Higher Education, N

Jurnal Pendidikan IPA Indonesia (Indonesian Journal of Science Education) [p-ISSN 2339-1286 | e-ISSN 2085
education in primary education, secondary education and higher education. This journal in collaborate with *Perkum*

This journal has been indexed in [Google Scholar](#), [DOAJ](#), [EBSCO](#), [SCOPUS](#)

Principal Contact



No r
cf
Start
n

 jpii@mail.unnes.ac.id

1

Manuscript Update Inbox x

**Jurnal Pendidikan IPA Indonesia**

to me

Dear Authors,

We are pleased to inform you that the reviewer has uploaded the review results of your article. Please check your OJS account for the newest review results. We are looking forward to your revision **not later** than May 29, 2020. Thank you.

Best regards,
JPII Team

Jurnal Pendidikan IPA Indonesia

Nationally Accredited based on the Decree of the Minister of Research, Technology and Higher Education, N

Jurnal Pendidikan IPA Indonesia (Indonesian Journal of Science Education) [p-ISSN 2339-1286 | e-ISSN 2085-4066] is a journal of science education in primary education, secondary education and higher education. This journal in collaborate with *Perkum*

This journal has been indexed in [Google Scholar](#), [DOAJ](#), [EBSCO](#), [SCOPUS](#)



No r
ct
Start
n

Zainuddin, Z., & Perera, C. J. (2017). Exploring students' competence, autonomy and relatedness in the flipped classroom pedagogical model. *Journal of Further and Higher Education*, 43(1), 115-126.



MINISTRY OF RESEARCH, TECHNOLOGY, AND HIGHER EDUCATION
 UNIVERSITAS NEGERI SEMARANG
 FACULTY OF MATHEMATICS AND NATURAL SCIENCES
 DEPARTMENT OF INTEGRATED SCIENCES
 IN COLLABORATION WITH PERKUMPULAN PENDIDIK IPA INDONESIA
JURNAL PENDIDIKAN IPA INDONESIA



p-ISSN: 2339-1286; e-ISSN: 2089-4392

Nationally Accredited Decree of The Minister of Research, Technology, and Higher Education No. 2/E/KPT/2015

SCOPUS INDEXED AND Q3 SCIMAGOJR

Secretariat: D5 Building, First Floor, UNNES Campus in SekaranGunungpati Semarang, Indonesia, Postal Code 50229.

Phone (+6224) 70805795, Fax. (+6224) 8508005, E-mail: ipii@mail.unnes.ac.id, Website: <http://journal.unnes.ac.id/nju/index.php/ipii>

Paper title: Assessing Prospective Biology Teachers' (PBTs) Perception on Thinking as 21st Century Skill; A Case Study Islamic University in Indonesia

Parts of review	Guidelines	Partly			Reviewer's note for improvement	Author's responds (highlight of revision)
		Yes	No	No		
Title	• Does the subject matter fit within the scope of journal?	√				
	• Does the title clearly and sufficiently reflect its contents?	√				
Abstract	• Does the abstract contain informative, including Background, Methods, Results and Conclusion?	√				
Back-ground	• Is the background informative and sufficient (include the background problem and objectives)?	√				
	• Is research question of the study clear and understandable?	√				
	• Does the rationale of the study clearly explained using relevant literature?	√				
	• Is the "aim" of the manuscript clear and	√				

	understandable?					
Methods	• Is the methodology chosen suitable to the nature of the topic studied?	√				
	• Is the methodology of the research described clearly?(including study design, location, subjects, data collection, data analysis)	√				
	• Is there adequate information about the data collection tools used? (only for empirical studies)	√				
	• Are the validity and reliability of data collection tools established? (only for empirical studies)	√				
	• Are the data collection tools suitable for the methodology of the study? (only for empirical studies)	√				
Results & Discussion	• Are the tables, graphs and pictures understandable, well presented and numbered consecutively?	√				
	• Do the data analysis and the interpretation appropriate to the problem and answer the objectives?	√				
	• Does the "discussion" section of the manuscript adequately relate to the current and relevant literature?	√				
	• Are the findings discussed adequately considering the research question(s), sub-question(s) or hypothesis?	√				
Conclusion	• Is the conclusion clear and in the form of a narration instead of pointers?	√				
	• Isn't the conclusion a summary and consistent between problems, objectives and conclusion?	√				
References	• Do the references and citations match?	√				
	• Are the writing of references correct?	√				
Quality Criteria	• Do the title, problem, objectives, methods and conclusion are in line? Is it well organized?	√				
	• The quality of the language is satisfactory	√				
	• The work relevant and novel	√				
	• Are there strong consistencies among the parts of the manuscript? (introduction, methods, results and discussion, and conclusion)	√				
General remarks					Only small revision for small grammatically error and typing	

Assessing Prospective Biology Teachers' (PBTs) Perception on Thinking as 21st Century Skill; A Case Study Islamic University in Indonesia

ABSTRACT

The explanatory mixed method was conducted to assess prospective biology teachers' (PBTs) perception on thinking as 21st century skills. Data were collected using a quantitative survey method, and an interview with PBTs from Islamic University. A total of 168 (14 men and 154 women) from 195 PBTs participated in filling out the questionnaire. The questionnaire consisted 24 statements of aspects of critical thinking, problem solving, creativity, metacognition of the 21st century skill. The confirmatory factor analysis (CFA) and alpha Cronbach tests was used to determine the quality of the instrument. Statistic descriptive, anova and correlation test was conducted to analyze the quantitative data. Triangulation was conducted on the results of the interview. The results of the study indicate that (a) most male and female PBTs at Islamic universities have high skills in critical thinking and metacognition; (b) most male and female PBTs at Islamic universities have insufficient skills in problem solving and creativity skills; (c) the results of this study also showed that there is no relationship between gender and PBTs skills.

Keywords: prospective biology teachers (PBTs), thinking, 21st century skill

INTRODUCTION

In education, the assessing of 21st century skills was the important issue (Geisinger, 2016), because its was conducted as a key concept and slogan in the field of education based 21st century skills (Greiff & Kyllonen, 2016). Teo (2019) also stated that over the past two decades, educators have determined strategies to prepare students and prospective teachers on how to navigate through the increasingly globalized world and inter-connected landscape associated with the 21st century. Because in the future, students needeed this skills (Larson & Miller, 2011). Additionally, Wang et al. (2018) reported that 21st century skills in the curriculum have also become an important issue throughout the world. Thus, these explanations show that other studies of 21st century skills from various perspectives and important fields are to be carried out, including in studies of 21st century skills involving prospective teacher students in the field of biology learning.

The authors has found a number of previous studies that have studied about 21st century skill for prospective biology teachers, such as: critical thinking (Maryuningsih et al., 2019; Fitriani et al., 2019), metacognitive (Chang et al., 2020; Listiana et al., 2016); ICT (Aslan & Zhu, 2017), problem solving (Nawani et al., 2019), generic science skill (Haviz et al., 2018), and creativity (Lucas, 2016). Maryuningsih et al. (2019) conducted quasi-experimental research to investigate the level of critical thinking skills (CTS) of 37 PBTs through online genetic discussion forums, and the results of research showed that the level of critical thinking skills of PBTs has increased based on the nature of chromosome inheritance learning through online discussion forums. Then, Fitriani et al. (2019) conducted research on the exploration of critical thinking of teacher candidates and critical analysis skills based on gender in anatomy and plant development courses, and the results showed that the PBTs critical thinking and critical analysis skills were underdeveloped and also found a positive correlation between the prospective teacher's critical thinking and critical analysis skills. Aslan & Zhu (2017) investigated that predicting variables Turkish pre-service science and other teachers' integration of ICT into teaching practice, and found that the use of ICT in pre-service teacher teaching programs increased the pedagogical ability of pre-service teachers. Chang et al. (2020) conducted a study of metacognitive inquiry activities to teach the central dogma concept of DNA replication and protein synthesis based on the metacognitive learning cycle (MLC) for students, and the results of this study showed that students' metacognition was expressed during the investigation process. Listiana et al. (2016) conducted a quasi-experimental research to compare the effect of group investigation (GI) strategy, think talk write, group investigation integrated with think talk write and conventional method on the students' metacognitive skills empowerment in biology classroom, and the results of the research showed that the implementation of teaching strategies had an effect to empower students' metacognitive skills.

These studies reported that also the importance of 21st century skills in learning biology. However, these studies have not classified the skills into a clearer terminology. Also, these studies only explore one skill in learning biology. In fact, many exploratory studies of 21st century skills can be done by teachers in the learning process. According to the authors, the terminology is needed to facilitate teachers integrating skills into the design and learning process. In addition, because the integrated learning process equips students with more competence (Zainuddin & Attaran, 2015). Thus, it is necessary to conduct studies that explore the 21st century skills more broadly, for example

Commented [Office1]: What is the suggestion based on the study?

Commented [Office2]: delete

Commented [Office3]: need

Commented [Office4]: 21st

Commented [Office5]: education

Commented [Office6]: delete

Commented [Office7]: delete

Commented [Office8]: delete

Commented [Office9]: not appropriate term, maybe not developed

Commented [Office10]: 21st

Commented [Office11]: 21st

Commented [Office12]: 21st

Commented [Office13]: broad

examining the types of skills required by PBTs. In addition, the study should begin with a study of the development of 21st century student skills and assessment instruments (Sondergeld & Johnson, 2019).

In this study, the authors follow the opinions and results of studies that have been written by Sondergeld and Jhonson (2019), where the importance of assessing the development and validation of 21st century skills using various methods and approaches. The results of the Sondergeld and Jhonson's study (2019) also showed that there are processes of planning, development, quantitative and qualitative tests and validation of 21st century skill instruments. In this study, the authors examine thinking as a 21st century skill written by Greenstein (2012). According to Greenstein (2012), there are three classifications of 21st century skills; thinking, acting and living are determined based on four skill levels. In this study, the use of different level of skills is assumed to be effective to capture responses of PBTs at Islamic universities in Indonesia. Because the 21st century skill assessment is effectively used at different levels of education.

In this study, also the authors investigated the relationship between gender and 21st century skills of PBTs. Because the authors found differences in the results of studies reported by previous researchers who had examined the relationship between gender and skill, or/and gender with achievement. Although, it is still being studied and debated, it is found that there are gaps in the learning outcomes of male and female students (Pederson, 2019; Alfarhan & Dauletova, 2019). For example, Kan'an (2018) results showed that there was a statistically significant difference between female and male students' mean scores of the Jordanian students' 21st century skills (Cs21). Also, Sladek et al. (2010) reported that there are gender and age differences in the thinking process, of men, adults, and teenagers. In addition, the results of other studies show that the ability to analyze and draw conclusions for male PBTs is more better than female PBTs (Fitriani et al., 2019). The findings of these three studies are understood as a form of a positive relationship between age and creative performance of students (Warren et al., 2018). However, the results of other previous studies also showed that there is no relationship between gender and learning outcomes (Reese et al., 2001; Ai, 1999; Rejskind et al., 1992). For examples, Rejskind et al. (1992) stated that no gender differences were found on the measures of personality and cognitive style, and no significant association was found between cognitive style and personality.

These explanation show that there is gap that can be explore with this study. This study will be approved these explanations. The three research objectives was to assessing: (1) the quality of the thinking skills instrument of PBTs; (2) the profile of the thinking skills of PBTs; and (3) the difference in the thinking skills of male and female PBTs.

Integrated Instruction at the Islamic University of Indonesia

Integrated instruction is learning that explores student knowledge broadly by combining various subjects of knowledge with environmental aspects, for example culture, communication, science, mathematics, social science, music and art (Drake & Reid, 2018). Haviz (2016) explains that learning is characterized by the unification and use of several materials, strategies, methods, approaches and other aspects of learning. According to the decision of the Directorate General of Islamic Education Ministry of Religion of the Republic of Indonesia Number 2498 in year 2019, integrated instruction was a characteristic of studying Islamic university in Indonesia. Previously, this integrated instruction was developed independently by each Islamic university in Indonesia. Since 2016, IAIN Batusangkar also implemented integrated instruction.

The application of Integrated instruction during the learning process refers to the university's integrative learning guidelines. The application of this integrated instrution improves student skills and learning outcomes. For example, research conducted by Haviz (2016) and Haviz et al. (2012). Both studies have integrated embryology with the Quran at Islamic universities. There are integrated instruction researches on their different respective content (Zainuddin & Perera, 2017; Agyei & Voogt, 2015; Holland & Piper, 2014). For example, Zainuddin & Perera (2017) identified the differences between a flipped classroom and a non-flipped classroom instructional model, and the results of the study showed that the out of class activities included the sharing of short video clips uploaded on to the institutional learning management system for students' access before class had successfully established the basic psychological needs of self determination theory.

However, a clear gap found in the application of integrated instruction in Islamic universities is not yet clearly determined the type of skills needed by students. If it is related to the application in class, there are not many reports of studies on the application and type of skills needed by students. So, this study investigates the skills required by PBTs at Islamic universities after the implementation of integrated instruction.

Thinking as 21st Century Skill

Thinking skills are part of the thinking, acting and living (TAL) framework, that consist of critical, problem-solving, creativity, and metacognition. In addition, critical thinking includes the concept of analyzing information,

Commented [Office14]: 21st

Commented [Office15]: 21st

Commented [Office16]: 21st

Commented [Office17]: 21st

Commented [Office18]: 21st

Commented [Office19]: 21st

Commented [Office20]: the author also

Commented [Office21]: 21st

Commented [Office22]: 21st

Commented [Office23]: delete

Commented [Office24]: assess

applying strategies, ideas, logical inquiry,...etc; problem solving is a basic process of identifying and choosing problems to be solved based on work understanding, brainstorming, choosing solutions, making plans,...etc and creativity includes curiosity, fluency, originality, elaboration, imagination and flexibility (Greenstein, 2012).

According to Elder (2017), critical thinking is associated with any subject, content, or problem where the participants skillfully improve the quality of their thinking. Also, there are 5 parts to critical thinking skills; clarification, support, conclusions, further clarification, and strategy (Wartono et al., 2018; Duran & Dokme, 2016). Bakir & Ozetekin (2014) state that creativity is an important skill for prospective teachers. Because creativity is a process of experience, limitation of habits, new ways and flexibility in solving problems (Belanger et al., 2011).

The fourth thinking skill is metacognition. Metacognition includes two components, knowledge and process based learning (Damar et al., 2015). In the classroom, aspects of metacognition are directed, forward-looking, conscious, self-regulated and flexible (Greenstein, 2012). Also, metacognitive skills contribute to student learning outcomes (Bahri & Corebima, 2015). Thus, an explanation of thinking as 21st century skills was summarized in Table 1. Table 1 illustrated the conceptual of four of thinking skills.

Table 1. The Four of Thinking Skill

Thinking skill	Critical thinking	Apply, evaluation, use of data, analysis, synthesis
	Problem solving	Identify the problem, applies problem solving, identifies solutions, evaluates solutions, defends solutions, applications, inductive and deductive reasoning
	Creativity	Curiosity, fluency, originality, elaboration, flexibility, divergents, messiness/risk taking
	Metacognition	Reflective, aware of thinking, strenghts and style, using metacognition

METHODS

This study used a mixed method, with an explanatory sequential design (Creswell, 2014). The reason for choosing this design is because quantitative findings are followed by qualitative findings, and both findings are strengthened by a more comprehensive explanation. Thus, this study expects the study outcomes of deep understanding or a more in-dept understanding of quantitative data.

This research utilized the quantitative method with a descriptive survey. A total of 168 (14 men and 154 women) from 195 PBTs participated in filling out the questionnaire. The goodness level of the research participants was in 2.82 %. The questionnaire consisted 24 statements of aspects of critical thinking, problem solving, creativity, metacognition of the 21st century skill (Greenstein, 2012). The questionnaire has a rating scale of 1-4, and the four levels were broadly described in Table 2.

Table 2. Rubric Terminology of 21st Century Skill

Level 4 Top tier = 3.6 to 4.0	Level 3 skilled tier = 3.2 to 3.5	Level 2 able tier = 2.8 to 3.1	Level 1 emerging tier = 2.0 to 2.7
Exemplary	Accomplished	Developing	Beginning
Advanced	Proficient	Basic	Novice
Excellent	Good	Fair	Poor
goes beyond requirements	meets requirements	some misconception	serious error
fully complete	mostly complete	Partial	Incomplete

To determine the validity of the instrument used the CFA Test. This test is often used to determine the quality of instruments and is considered a credible way by previous researchers such as Suhr (2018); Chai et al. (2015); Jia et al. (2016); and Sang et al. (2018). The Cronbach Alpha test was used to determine the reliability of the instrument. To determine the PBTs thinking skill profile in the form of average values and standard deviations, raw data were analyzed with descriptive statistics. PBT skill levels are displayed as a percentage. Anova test was used to determine differences in male and female PBTs thinking skills. And, the correlation test is used to determine the relationship between gender and thinking factors.

In the qualitative test, in-depth interviews were conducted with 5 male PBTs and 7 female PBTs. Interviews were conducted separately between one respondent and another respondent. Interview questions given to respondents were developed according to the questionnaire indicators in the quantitative test. Triangulation was conducted on the results of the interview. Steps such as verification, display and conclusion drawing from data are carried out to obtain or justify more valid and reliable information.

RESULTS AND DISCUSSION

CFA and Alpha Cronbach Test Results

The CFA test results showed that the *Chi Square score* = 2.69, *df* = 2, *P-value* = 0.26087 and *RMSEA* = 0.045. The reliability test results show that the *Cronbach's Alpha score* = .844 with *N of Items* = 24. Based on the pictures it can be concluded that all of the items (24 items) presented are valid because based on the image at the *T-Value* position there is no arrow from each indicator that was coloured Red. This finding indicates that all items are valid. In addition, the results on the p-value of each item indicate that for all items the p-value is smaller than alpha divided by the number of items. The results of the p-value are all items smaller than alpha divided by the number of items, it can be concluded that all items measuring each indicator of thinking are valid.

Furthermore, in the fig. 1 Standardized Solution found only one item or factor load whose number is less than 0.3. This finding indicates that points 2 to 24 can be said to be valid. Thus, the validity coefficient can be considered satisfactory if it exceeds the 0.1 (Suhr, 2018). Furthermore, Suhr (2018) stated that CFA is a picture of simplification of interrelated steps and the number of constructs and factor structures to determine the content or meaning of these factors. In addition, the findings of this study are also in line with studies conducted by Jia et al. (2016). Regarding the use of Cronbach's alpha as a reliability test, Taber (2018) has said that (a) Cronbach's alpha is a statistic used by the author to show that tests and scales that have been built or adopted for research projects, and (b) high alpha values provide limited evidence of the reliability of research instruments

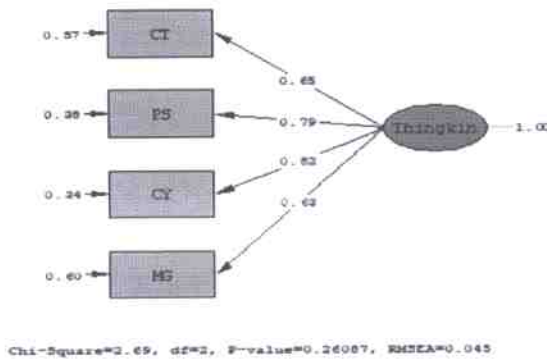

Figure 1. Confirmatory Factor Analysis for Critical Thinking, Problem Solving, Creativity, Metacognition for Standardized Solution

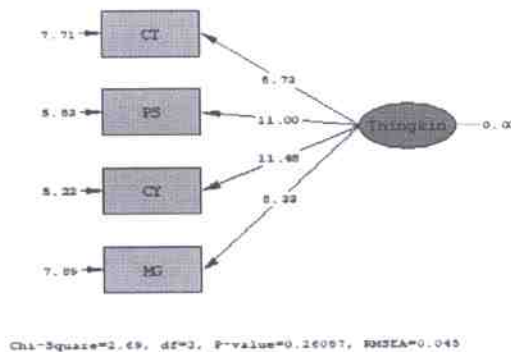

Figure 2. Conformatory Factor Analysis for Critical Thinking, Problem Solving, Creativity, Metacognition for T-Value

Profile of Thinking Skill PBTs

Table 3. Descriptive Statistics for The Profile of PBTs Thinking Skills

Thinking Skill	PBTs Skill Level (%)							
	Novice		Basic		Proficient		Exemplary	
	Male	Female	Male	Female	Male	Female	Male	Female
Critical thinking	0.11	0.09	0.16	0.16	0.33	0.21	0.40	0.44
Problem solving	0.07	0.06	0.25	0.30	0.38	0.34	0.24	0.23
Creativity	0.09	0.09	0.29	0.35	0.33	0.28	0.29	0.20
Metacognition	0.12	0.17	0.23	0.25	0.27	0.28	0.40	0.34
Total	0.39	0.41	0.93	1.06	1.31	1.11	1.33	1.21
Average	0.098	0.103	0.233	0.265	0.328	0.278	0.333	0.303
SD	0.022	0.047	0.054	0.081	0.045	0.053	0.081	0.11

Table 3 showed that the highest score for critical thinking was found at the exemplary level. The highest critical thinking score for male PBTs was 0.40%, and the highest critical thinking score for female PBTs was 0.44%. Then, the lowest critical thinking score was found at the novice level. The lowest critical thinking score for male PBTs was 0.11%, and the lowest critical thinking score for female PBTs was 0.09%.

The highest score for critical thinking was found at the exemplary level. The highest critical thinking score for male PBTs was 0.40%, and the highest critical thinking score for female PBTs was 0.44%. The lowest critical thinking score was found at the novice level. The lowest critical thinking score for male PBTs was 0.11%, and the lowest critical thinking score for female PBTs was 0.09%.

In contrast to critical thinking, the highest score for problem solving was found at a proficient level. The highest problem solving score for male PBTs was 0.38%, and the highest problem solving score for female PBTs was 0.34%. The lowest score for problem solving was found at the novice level. The lowest problem solving score for male PBTs was 0.07%, and the lowest problem solving score for female PBTs was 0.06%.

The study findings on creativity differ from both critical thinking and problem solving. The highest score for creativity skills was found at different skill levels. The highest creativity score for male PBTs was 0.33%, which was found at the professional level. The highest creativity score for female PBTs was 0.35%, which is found at the basic level. The lowest creativity score was found at the novice level. The lowest creativity score for prospective male and female PBTs was 0.09.

Similar to critical thinking, the highest score for metacognition was found at the exemplary level. The highest metacognition score for male PBTs was 0.40%, and the highest metacognition score for female PBTs was 0.34%. The lowest score for metacognition was found at the novice level. The lowest metacognition score for male PBTs was 0.12%. The lowest metacognition score for female PBTs was 0.17%.

The results of this study indicate that novice was the lowest skill level for the four types of skills e.g critical thinking, problem solving, creativity, and metacognition. The highest level for critical thinking and metacognition was found in exemplaries, and the highest level for problem solving and creativity was found in proficient, although the highest score of creativity for female biology teacher candidates was found at the basic level.

Interview results are similar to the results of descriptive statistical tests. PBTs answer questions that indicate that their critical thinking and metacognition skills are at a good level. The transcript of interviews with PBTs about the application of critical thinking skills in the learning process wrote in the following section.

1. Researcher: In the aspect of applying critical thinking to the learning process, do you have a good understanding of the theories and facts related to the learning material?
PBTs: I have a poor understanding of facts, principles and everything needed to help me understand the problem in learning
2. Researcher: In the aspect of using analysis in the learning process, do you use it? How do you apply the analysis in the learning process?

Commented [Office25]: shows

PBTs: With help, I can understand the problem directly and draw simple conclusions after being helped by others, especially by classmates. Sometimes I explain the main problems inaccurately. But I cannot contemplate it carefully in an objective way

The transcript of interviews with PBTs about the application of metacognition skills in the learning process wrote in the following section.

1. Researcher: How do you reflect on your thinking in learning?
PBTs: I need a visual or verbal structure to help me reflect on thoughts or with the help of others, I can improve thought reflection
2. Researcher: Do you use metacognitive when studying? How do you do it?
PBTs: I use my metacognitive abilities to improve my learning and productivity. I routinely apply it in daily practice

Also, PBTs answer questions that indicate that their problem solving and creativity skills are at a less or enough level. The transcript of interviews with PBTs about the application of problem solving skills in the learning process wrote in the following section.

1. Researcher: Do you use analysis and synthesis in the learning process?
PBTs: With the help of others, I can understand the problem directly and draw simple conclusions. But sometimes I explain the main problems inaccurately. But I cannot contemplate it carefully in an objective way. So as to combine and connect difficult ideas. So, I am less able to compile two different ideas, see a direct pattern, and summarize it
2. Researcher: In the aspect of using evaluation in the learning process, do you have the ability to evaluate learning material?
PBTs: The ability to evaluate objects, settings or performance that I have is quite clear, especially related to the criteria or standards given by the lecturer in learning, so that I can use and understand the evaluation process accurately

The transcript of interviews with PBTs about the application of creativity skills in the learning process wrote in the following section.

1. Researcher: How do you elaborate and focus creativity while learning?
PBTs: Maybe some ideas come to me if I'm really working hard and usually I can find a way to make it better. I can do one or two but my idea is relatively simple. I can do two or three things with the process: merge, modify, adjust, or rearrange
2. Researcher: Do you study and work when you do it with flexible creativity?
PBTs: Sometimes it's hard for me to adjust to change. When someone reminds me to think differently, I can usually do it. So that I cannot work effectively even when things change and pay attention to the potential of some things when I study

The difference in the thinking skills of male and female PBTs

Anova has been conducted to differentiate thinking skills between male and female PBTs. Before, a homogeneity test was also carried out, and the results of the test of homogeneity of variances showed that the *Levene Statistics score* = .904, *df1* = 1; *df2* = 670 and *Sig.* = .342. So it was concluded that found the similarity of variance and ANOVA test can be done. Anova test results showed on Table 4, that there are significant differences thinking skills of male and female PBTs (*F score*; 7157, *p* > 0.05). So, it was concluded that there were differences in thinking of male and female PBTs at Islamic universities.

Table 4. Anova Scores for Different of Thinking skills PBTs

	Sum of Squares	df	Mean Square	F	Sig.
Between Groups	1505.194	1	1505.194	7.157	.008
Within Groups	140911.179	670	210.315		
Total	142416.373	671			

Furthermore, correlation tests carried out to determine the relationship and interaction between gender variables (male and female) with the type of thinking (critical thinking, problem solving, creativity, and metacognition). The correlation test data for gender variables with thinking factors showed on Table 5.

Table 5. Correlation for Gender and Factor of Thingking Skill

Source	Type III Sum of Squares	Df	Mean Square	F	Sig.
Corrected Model	18011.475 ^a	7	2573.068	13.734	.000
Intercept	1028200.944	1	1028200.944	5487.930	.000
JK	1505.194	1	1505.194	8.034	.005
Indicator	1872.895	3	624.298	3.332	.019

JK * Indicator	1105.865	3	368.622	1.967	.118
Error	124404.898	664	187.357		
Total	3296276.283	672			
Corrected Total	142416.373	671			
a. R Squared = .126 (Adjusted R Squared = .117)					

The results of the study showed that there is no relationship between gender with the thinking skills factor. Because, the finding indicated that (a) There was a difference in the thinking skills of male and female PBTs ($F=8.034$, $P>0.05$); (b) There was differences in the ability of PBTs based on indicators ($F=3.332$, with a significance of 0.019); and (c) There was no interaction of Gender with factors ($F=1.967$, with a significance of 0.118).

This study was found that there was no relationship between gender and PBT skills. The findings of this study were coherent with research conducted by previous researchers in biology learning. Hadjichambis et al. (2016) was found that gender is only a factor that will function as a mediator in learning about human reproduction. Furthermore, in the study of toxic and non-toxic plants, no differences were found in the identification skills of poisonous plants with regard to age and sex (Prokop & Fančovičová, 2019). Špernjak & Šorgo (2018) have researched about testing differences in the knowledge gained and students' preferences for various technologies in biology laboratory work, and the results of this study showed that there were no statistical differences related to the acquisition of student knowledge between these laboratory technologies with respect to grades, gender or school score. And there are other factors that determine learning outcomes, namely the level of education in learning biology (Fonseca et al., 2012).

The study results showed that PBTs gave their opinion that the need to increase mastery in problem solving and creativity skills. On the other hand, for critical thinking and metacognition skills, PBTs gave the opinion that they already have good skills. This finding means that the applied integrative learning has not yet had an impact or has not targeted problem solving and creativity skills for PBTs. On the other hand, integrative learning has targeted critical thinking and metaconition skills.

In this study, problem solving and creativity were less mastered competencies but it is important to be taught to prospective biology teacher students. Both of these skills involve the process of (a) describing problems with depth and clarity, (b) looking at problems with an open mind, evaluating alternatives, and considering various perspectives, (c) gathering information to make informed choices and developing plans, (d) applying and monitor with integrity and (e) evaluate the results and be willing to review the problem (Greenstein, 2012). Furthermore, this study also shows that students' problem solving skills increase when applying problem-based learning (Argaw et al., 2017).

In this study, there are four skills that reviewed and consulted with the PBTs. The findings of this study was in line with the results of studies conducted by Afandi et al. (2019). The study results showed that there are four competencies in The Indonesian Parnertships 21st Century Skills (IP-21CS) for prospective science teacher students, namely (1) 4Cs (critical thinking, creative thinking, collaboration and communication); (2) ICTs (technology, media and information literacy); (3) spiritual values (religious beliefs and spiritual awareness); and (4) charactel building (teachers' attitude and scientific attitudes).

CONCLUSION

The findings in this study indicated that; (a) The most of male and female PBTs at Islamic universities have high skills in critical thinking and metacognition; (b) The most male and female PBTs at Islamic universities have insufficient skills in problem solving and creativity skills; (c) The results of this study show that there is no relationship between gender and PBT skills.

The results of this study can be used as criticism for educational management majors in biology education in Indonesia, especially at Islamic Universities. Educational managers need to pay attention that the application of integrative learning needs to pay attention to the skills required by PBTs. For this reason, learning applied in classrooms must be based on 21st century skills.

ACKNOWLEDGEMENTS

This work was supported by IAIN Batangkar (grant numbers B-870.a/In 27/R. IV/TL.00/04/2019).

REFERENCES

- Afandi, A., Sajidan, S., Akhyar, M., & Suryani, N. (2019). Development Frameworks of the Indonesian Partnership 21st-Century Skills Standards for Prospective Science Teachers: A Delphi Study. *Jurnal Pendidikan IPA Indonesia*, 8(1), 89-100.
- Agyei, D. D., & Voogt, J. M. (2015). Pre-service teachers' TPACK competencies for spreadsheet integration: insights from a mathematics-specific instructional technology course. *Technology, Pedagogy and Education*, 24(5), 605-625.
- Ai, X. (1999). Creativity and academic achievement: an investigation of gender differences. *Creativity Research Journal*, 12(4), 329-337.
- Alfarhan, U. F., & Dauletova, V. (2019). Revisiting the gender academic achievement gap: evidence from a unique environment. *Gender and Education*, 31(7), 827-848.
- Argaw, A. S., Haile, B. B., Ayalew, B. T., & Kuma, S. G. (2017). The effect of problem based learning (pbl) instruction on students' motivation and problem solving skills of physics. *Eurasia Journal of Mathematics Science and Technology*, 13(3), 857-871.
- Aslan, A., & Zhu, C. (2017). Investigating variables predicting Turkish pre-service teachers' integration of ICT into teaching practices. *Br J Educ Technol*, 48(2), 552-570.
- Bahri, A., & Corebima, A. D. (2015). The contribution of learning motivation and metacognitive skill on cognitive learning outcome of students within different learning strategies. *Journal of Baltic Science Education*, 14(4), 487-500.
- Bakır, S., & Öztekin, E. (2014). Creative thinking levels of preservice science teachers in terms of different variables. *Journal of Baltic Science Education*, 13(2), 231-242.
- Bélanger, R. E., Akre, C., Berchtold, A., & Michaud, P. A. (2011). A U-shaped association between intensity of Internet use and adolescent health. *Pediatrics*, 127(2), 330-335.
- Chai, C. S., Deng, F., Tsai, P. S., & Koh, J. H. (2015). Assessing multidimensional students' perceptions of twenty-first-century learning practices. *Asia Pacific Education Review*, 16(3), 389-398.
- Chang, P. S., Lee, S. H., & Wen, M. L. (2020). Metacognitive inquiry activities for instructing the central dogma concept: 'button code' and 'beaded bracelet making. *Journal of Biological Education*, 54(1), 47-62.
- Creswell, J. W. (2014). *Research Design: Quantitative, Qualitative and Mixed Method Approaches* (4th ed.). California: SAGE Publication, Inc.
- Damar, S. Y., Özdemir, Ö. F., & Unal, C. (2015). Pre-service physics teachers' metacognitive knowledge about their instructional practices. *Eurasia Journal of Mathematics, Science & Technology Education*, 11(5), 1009-1026.
- Drake, S. M., & Reid, J.L. (2018). Integrated curriculum as an effective way to teach 21st century capabilities. *Asia Pacific Journal of Educational Research*, 1(1), 31-50.
- Duran, M., & Dökme, I. (2016). The effect of the inquiry-based learning approach on student's critical-thinking skills. *Eurasia Journal of Mathematics, Science & Technology Education*, 12(12), 2887-2908.
- Elder, L. (2007). Another brief conceptualization of critical thinking. Retrieved from <http://www.criticalthinking.org/pages/defining-critical-thinking/766>.
- Fitriani, H., Asy'ari, M., Zubaidah, S., & Mahanal, S. (2019). Exploring the prospective teachers' critical thinking and critical analysis skills. *Jurnal Pendidikan IPA Indonesia*, 8(3), 379-390.
- Fonseca, M. J., Costa, P., Lencastre, L., & Tavares, F. (2012). Multidimensional analysis of high-school students' perceptions about biotechnology. *Journal of Biological Education*, 46(3), 129-139.
- Geisinger, K. F. (2016). 21st century skills: What are they and how do we assess them? *Applied Measurement in Education*, 29(4), 245-249.
- Greenstein, L. (2012). *Assesing 21st century skill. a guide to evaluating mastery and authentic learning*. California: SAGE Company. Retrieved from <https://eric.ed.gov/?id=ED534306>.
- Greiff, S., & Kyllonen, P. (2016). Contemporary assessment challenges: the measurement of 21st century skills. *Applied Measurement in Education*, 29(4), 243-244.
- Hadjichambis, A., Ch., Georgiou, Y., Hadjichambi, D. P., Kyza, E. A., & Mappouras, D. (2016). Investigating the effectiveness of an inquiry-based intervention on human reproduction in relation to students' gender, prior knowledge and motivation for learning in biology. *Journal of Biological Education*, 50(3), 261-274.
- Haviz, M. (2016). Designing and developing the integrated learning model on embryology. *Transylvanian Review*, 24(7), 1043-1052.
- Haviz, M., Karomah, H., Delfita, R., Umar, M. I. A., & Maris, I. M. (2018). Revisiting generic science skills as 21st century skills on biology learning. *Jurnal Pendidikan IPA Indonesia*, 7(3), 355-363.

Commented [U26]: old source, use article taken from the last 10 years (>2010) of no-predatory journals, written in accordance with the APA Standard.

- Haviz, M., Lufri, Fauzan, A., & Efendi, Z. M. (2012). Pengembangan model pembelajaran integratif pada biologi perkembangan hewan: analisis kebutuhan pengembangan. *Ta'dib*, 15(1), 1-14.
- Holland, D. D., & Piper, R. T. (2014). A technology integration education (TIE) model: Millennial preservice teachers' motivations about technological, pedagogical, and content knowledge (TPACK) competencies. *Journal of Educational Computing Research*, 51(3), 257-294.
- Jia, Y., Oh, Y. J., Sibuma, B., LaBanca, F., & Lorentson, M. (2016). Measuring twenty-first century skills: development and validation of a scale for in-service and pre-service teachers. *Teacher Development: An International Journal of Teachers' Professional Development*, 20(2), 229-252.
- Kan'an, A. (2018). The relationship between Jordanian students' 21st century skills (Cs21) and academic achievement in science. *Journal of Turkish Science Education*, 15(2), 82-94.
- Larson, L. C., & Miller, T. N. (2011). 21st century skills: Prepare students for the future. *Kappa Delta Pi Record*, 47(3), 121-123.
- Listiana, L., Susilo, H., Suwono, H., & Suarsini, E. (2016). Empowering students' metacognitive skills through new teaching strategy (group investigation integrated with think talk write) in biology classroom. *Journal of Baltic Science Education*, 15(3), 391-400.
- Lucas, B. (2016). A five-dimensional model of creativity and its assessment in schools. *Applied Measurement in Education*, 29(4), 278-290.
- Maryuningsih, Y., Hidayat, T., Riandi, R., & Rustaman, N. (2019). Critical thinking skills of prospective biology teacher on the chromosomal basic of inheritance learning through online discussion forums. *J. Phys.: Conf. Ser.* 1157 022090.
- Nawani, J., Kotzebue, L. V., Spangler, M., & Neuhaus, B. J. (2019). Engaging students in constructing scientific explanations in biology classrooms: a lesson-design model. *Journal of Biological Education*, 53(4), 378-389.
- Pedersen, J. M. (2019). Gender achievement gaps: Reexamining the transformational debate. *Childhood Education*, 95(5), 74-78.
- Prokop, P & Fančovičová, J. (2019). The perception of toxic and non-toxic plants by children and adolescents with regard to gender: implications for teaching botany. *Journal of Biological Education*, 53(4), 463-473.
- Reese, H.W., Lee, L.J., Cohen, S. H., & Puckett Jr, J. M. (2001). Effects of intellectual variables, age, and gender on divergent thinking in adulthood. *International Journal of Behavioral Development*, 25(6), 491-500.
- Rejskind, F.G., Rapagna, S. O., & Gold, G. (1992). Gender differences in children's divergent thinking. *Creativity Research Journal*, 5(2), 165-174.
- Sang, G., Liang, J. C., Chai, C. S., Dong, Y., & Tsai, C. C. (2018). Teachers' actual and preferred perceptions of twenty-first century learning competencies: a Chinese perspective. *Asia Pacific Education Review*, 19(3), 307-317.
- Sladek, R.M., Bond, M.J., & Phillips, P.A. (2010). Age and gender differences in preferences for rational and experiential thinking. *Personality and Individual Differences*, 49(8), 907-911.
- Sondergeld, T. A., & Johnson, C. C. (2019). Development and validation of a 21st Century Skills Assessment: Using an iterative multi method approach. *School Science and Mathematics*, 119, 312-326.
- Špernjak, S., & Šorgo, A. (2018). Differences in acquired knowledge and attitudes achieved with traditional, computer-supported and virtual laboratory biology laboratory exercises. *Journal of Biological Education*, 52(2), 206-220.
- Suhr, D. D. (2018). *Exploratory or Confirmatory Factor Analysis?* Retrived from <http://www2.sas.com/proceedings/sugi31/200-31.pdf>
- Taber, K. S. (2018) The use of Cronbach's Alpha when developing and reporting research instruments in science education. *Res Sci Educ* 48(6):1273-1296.
- Teo, P. (2019). Teaching for the 21st century: A case for dialogic pedagogy. *Learning, Culture and Social Interaction*, 21, 170-178.
- Wang, Y., Lavonen, J., & Tirri, K. (2018). Aims for learning 21st century competencies in national primary science curricula in china and finland. *Eurasia Journal of Mathematics, Science and Technology Education*, 14(6), 2081-2095.
- Warren, F., Apps, E. M., Hoskins, S., Azmi, Z., & Boyce, J. (2018). The role of implicit theories, age, and gender in the creative performance of children and adults. *Thinking Skills and Creativity*, 28, 98-109.
- Wartono, W., Hudha, M. N., & Batlolona, J. R. (2018). How are the physics critical thinking skills of the students taught by using inquiry-discovery through empirical and theoretical overview? *Eurasia Journal of Mathematics Science and Technology*, 14(2), 691-697.
- Zainuddin, Z., & Attaran, M. (2015). Malaysian students' perceptions of flipped classroom: A case study. *Innovations in Education and Teaching International* 53(6): 660-670.

Paper title:

Assessing Prospective Biology Teachers' (PBTs) Perception on Thinking as 21st Century Skill; A Case Study Islamic University in Indonesia

Parts of review	Guidelines	Yes	Partly	No	Reviewer's note for improvement	Author's responds (highlight of revision)
Title	• Does the subject matter fit within the scope of journal?	√				
	• Does the title clearly and sufficiently reflect its contents?		√			
Abstract	• Does the abstract contain informative, including Background, Methods, Results and Conclusion?		√			
Back-ground	• Is the background informative and sufficient (include the background problem and objectives)?		√			
	• Is research question of the study clear and understandable?		√			
	• Does the rationale of the study clearly explained using relevant literature?		√			
Methods	• Is the "aim" of the manuscript clear and understandable?		√			
	• Is the methodology chosen suitable to the nature of the topic studied?		√			
	• Is the methodology of the research described clearly?(including study design, location, subjects, data collection, data analysis)		√			
	• Is there adequate information about the data collection tools used? (only for empirical studies)		√			
	• Are the validity and reliability of data collection tools established? (only for empirical studies)	√				
Results & Discussion	• Are the data collection tools suitable for the methodology of the study? (only for empirical studies)	√				
	• Are the tables, graphs and pictures understandable, well presented and numbered consecutively?	√				
	• Do the data analysis and the interpretation appropriate to the problem and answer the objectives?		√			
	• Does the "discussion" section of the manuscript adequately relate to the current and relevant literature?		√			
Conclusion	• Are the findings discussed adequately considering the research question(s), sub-question(s) or hypothesis?		√			
	• Is the conclusion clear and in the form of a narration instead of pointers?		√			
	• Isn't the conclusion a summary and consistent between problems, objectives and conclusion?		√			

References	• Do the references and citations match?		√			
	• Are the writing of references correct?		√			
Quality Criteria	• Do the title, problem, objectives, methods and conclusion are in line? Is it well organized?		√			
	• The quality of the language is satisfactory		√			
	• The work relevant and novel		√			
	• Are there strong consistencies among the parts of the manuscript? (introduction, methods, results and discussion, and conclusion)		√			

Assessing Prospective Biology Teachers' (PBTs) Perception on Thinking as 21st Century Skill; A Case Study Islamic University in Indonesia

M. Haviz¹, Lufri²

¹ Institut Agama Islam Negeri (IAIN) Batusangkar, Indonesia

² Universitas Negeri Padang

*Correspondence Address: mhaviz@iainbatusangkar.ac.id

ABSTRACT

The explanatory mixed method was conducted to assess prospective biology teachers' (PBTs) perception on thinking as 21st century skills. Data were collected using a quantitative survey method, and an interview with PBTs from Islamic University. A total of 168 (14 men and 154 women) from 195 PBTs participated in filling out the questionnaire. The questionnaire consisted of 24 statements of aspects of critical thinking, problem solving, creativity, metacognition of the 21st century skill. The confirmatory factor analysis (CFA) and alpha Cronbach tests were used to determine the quality of the instrument. Descriptive, ANOVA and correlation tests were conducted to analyze the quantitative data. Triangulation was conducted on the results of the interview. The results of the study indicate that (a) most male and female PBTs at Islamic universities have high skills in critical thinking and metacognition; (b) most male and female PBTs at Islamic universities have insufficient skills in problem solving and creativity skills; (c) the results of this study also show that there is no relationship between gender and PBTs skills.

Keywords: prospective biology teachers (PBTs), thinking, 21st century skill

INTRODUCTION

In education, the assessing of 21st century skills was the important issue (Geisinger, 2016), because it was conducted as a key concept and slogan in the field of education based on 21st century skills (Greiff & Kyllonen, 2016). Teo (2019) also stated that over the past two decades, educators have determined strategies to prepare students and prospective teachers on how to navigate through the increasingly globalized world and inter-connected landscape associated with the 21st century. Because in the future, students need these skills (Larson & Müller, 2011). Additionally, () report that 21st century skills in the curriculum have also become an important issue throughout the world.

The authors have found a number of previous studies that have studied about 21st century skill for prospective biology teachers, such as: critical thinking (), metacognitive (), ICT (Aslan & Zhu, 2017), problem solving (Nawani, Kotzebue, Spangler, & Neuhaus, 2019), generic science skill (Haviz, Karomah, Delfita, Umar & Maris, 2018), and creativity (Lucas, 2016).

Maryuningsih, Hidayat, Riandi, and Rustaman (2019) conducted quasi-experimental research to investigate the level of critical thinking skills (CTS) of 37 PBTs through online genetic discussion forums, and the results of research showed that the level of critical thinking skills of PBTs has increased based on the nature of chromosome inheritance learning through online discussion forums. Then, Fitriani, Asy'ari, Zubaidah, and Mahanal (2019) conducted research on the exploration of critical thinking of teacher candidates and critical analysis skills based on gender in anatomy and plant development courses, and the results showed that the PBTs' critical thinking and critical analysis skills were underdeveloped and also found a positive correlation between the prospective teacher's critical thinking and critical analysis skills. Aslan and Zhu (2017) investigated that predicting variables Turkish pre-service science and other teachers' integration of ICT into teaching practice, and found that the use of ICT in pre-service teacher teaching programs increased the pedagogical ability of pre-service teachers. Chang, Lee, and Wen (2020) conducted a study of metacognitive inquiry activities to teach the central dogma concept of DNA replication and protein synthesis based on the metacognitive learning cycle (MLC) for students, and the results of this study showed that students' metacognition was expressed during the investigation process. () conducted a quasi-experimental research to compare the effect of group investigation (GI) strategy, think talk write, group investigation integrated with think talk write and conventional method on the students' metacognitive skills empowerment in biology classroom, and the results of the research showed that the implementation of teaching strategies had an effect to empower students' metacognitive skills.

These studies have reported that the importance of 21st century skills in learning biology. However, these studies have not classified the skills into a clearer terminology. Also, these studies only explore one skill in learning

Commented [U1]: INTRODUCTION should:

- contain urgency (importance) to research
- contain a carrying capacity in the form of supporting data and facts
- contain a preliminary study as a basis for the importance of the research conducted
- contain a GAP ANALYSIS Departing from the preliminary study, analysis of published articles formulated in the Gap analysis

GAP ANALYSIS refers to articles published in various internationally reputable journals to emphasize the novelty of research.

- clear limitation of research objectives

Commented [U2]: Use et al for more than 2 authors

Commented [U3]: Use &

biology. In fact, many exploratory studies of 21st century skills can be done by teachers in the learning process. According to the author, the terminology is needed to facilitate teachers integrating skills into the design and learning process. In addition, because the integrated learning process equips students with more competence (Zainuddin & Attaran, 2015). Thus, it is necessary to conduct studies that explore the 21st century skills more broadly, for example examining the types of skills required by PBTs. In addition, the study should begin with a study of the development of 21st century student skills and assessment instruments ().

In this study, the authors follow the opinions and results of studies that have been written by (), where the importance of assessing the development and validation of 21st century skills using various methods and approaches. The results of the () also showed that there are processes of planning, development, quantitative and qualitative tests and validation of 21st century skill instruments. In this study, the authors examine thinking as a 21st century skill written by Greenstein (2012). According to Greenstein (2012), there are three classifications of 21st century skills; thinking, acting and living are determined based on four skill levels. In this study, the use of different level of skills is assumed to be effective to capture responses of PBTs at Islamic universities in Indonesia. Because the 21st century skill assessment is effectively used at different levels of education ().

In this study, also the authors investigated the relationship between gender and 21st century skills of PBTs. Because the authors found differences in the results of studies reported by previous researchers who had examined the relationship between gender and skill, or/and gender with achievement. Although, it is still being studied and debated, it is found that there are gaps in the learning outcomes of male and female students (). For example, Kan'an (2018) results showed that there was a statistically significant difference between female and male students' mean scores of the Jordanian students' 21st century skills (Cs21). Also, () reported that there are gender and age differences in the thinking process, of men, adults, and teenagers. In addition, the results of other studies show that the ability to analyze and draw conclusions for male PBTs is more better than female PBTs (). The findings of these three studies are understood as a form of a positive relationship between age and creative performance of students ().

However, the results of other previous studies also show that there is no relationship between gender and learning outcomes (Reese, Lee, Cohen, & Puckett, 2001, Ai, 1999, Rejskind, Rapagna, & Gold, 1992). For examples, Rejskind, Rapagna, & Gold (1992) stated that no gender differences were found on the measures of personality and cognitive style, and no significant association was found between cognitive style and personality.

Integrated Instruction at the Islamic University of Indonesia

Integrated instruction is learning that explores student knowledge broadly by combining various subjects of knowledge with environmental aspects, for example culture, communication, science, mathematics, social science, music and art (Drake & Reid, 2018). Haviz (2016) explains that learning is characterized by the unification and use of several materials, strategies, methods, approaches and other aspects of learning.

According to the decision of the Directorate General of Islamic Education Ministry of Religion of the Republic of Indonesia Number 2498 in year 2019, integrated instruction was a characteristic of studying Islamic university in Indonesia. Previously, this integrated instruction was developed independently by each Islamic university in Indonesia. Since 2016, IAIN Batusangkar also implemented integrated instruction.

The application of Integrated instruction during the learning process refers to the university's integrative learning guidelines. The application of this integrated instruction improves student skills and learning outcomes. For example, research conducted by Haviz (2016), and (). Both studies have integrated embryology with the Quran at Islamic universities. Although with different content, research conducted by Zainuddin & Perera (2017), Agyeri & Voogt (2015) and Holland & Piper (2014) are integrated instruction researches on their respective content. For example, Zainuddin & Perera (2017) identified the differences between a flipped classroom and a non-flipped classroom instructional model, and the results of the study showed that the out of class activities included the sharing of short video clips uploaded on to the institutional learning management system for students' access before class had successfully established the basic psychological needs of self determination theory.

However, a clear gap found in the application of integrated instruction in Islamic universities is not yet clearly determined the type of skills needed by students. If it is related to the application in class, there are not many reports of studies on the application and type of skills needed by students. So, this study investigates the skills required by PBTs at Islamic universities after the implementation of integrated instruction.

Thinking as 21st Century Skill

Greenstein (2012) has written that thinking skills are part of the thinking, acting and living (TAL) framework. Then, Greenstein (2012) also stated that the thinking skills consist of critical, problem-solving, creativity, and metacognition. According to Elder (2017), critical thinking is associated with any subject, content, or problem where the participants skillfully improve the quality of their thinking. In addition, Greenstein (2012) also stated that critical thinking includes the concept of analyzing information, applying strategies, ideas, logical inquiry, making conclusions, evaluating evidence, accurate judgments, and analyzing assumptions. Also, there are 5 parts to critical thinking skills; clarification, support, conclusions, further clarification, and strategy (Wartono, Huda, and Batlolona, 2018; Duran & Dokme, 2016). The second thinking skill is problem solving. According to Greenstein (2012), problem solving is a basic process of identifying and choosing problems to be solved based on work; understanding, brainstorming, choosing solutions, making plans, implementing plans, and evaluating results.

The third thinking skill is creativity. The characteristics of creativity; (a) curiosity, such as probing, asking questions, searching for deeper meaning, (b) fluency, such as the production of a number of ideas, (c) originality, such as new, fresh, unique or unusual ideas, (d) elaboration, such as ideas that display intensive details or add to existing details, (e) imagination, such as dreaming, discovering new ideas or products, ingenuity and (f) flexibility, such as ideas that show various possibilities (Greenstein, 2012). Bakir and Ozetekin (2014) state that creativity is an important skill for prospective teachers. Because creativity is a process of experience, limitation of habits, new ways and flexibility in solving problems (Belanger, Acre, Berchtold, & Michaud, 2011).

The fourth thinking skill is metacognition. Metacognition includes two components, knowledge and process based learning (Greenstein, 2012). In the classroom, aspects of metacognition are directed, forward-looking, conscious, self-regulated and flexible (Greenstein, 2012). Also, metacognitive skills contribute to student learning outcomes (Bahri & Corebima, 2015).

Thus, an explanation of thinking as 21st century skills was summarized in Table 1. Table 1 illustrated the conceptual of four of thinking skills. To conduct the study, three research objectives of this study to assessing; (1) the quality of the thinking skills instrument of PBTs; (2) the profile of the thinking skills of PBTs; and (3) the difference in the thinking skills of male and female PBTs.

Table 1. The four of thinking skill

Thinking skill	Critical thinking	Apply, evaluation, use of data, analysis, synthesis
	Problem solving	Identify the problem, applies problem solving, identifies solutions, evaluates solutions, defends solutions, applications, inductive and deductive reasoning
	Creativity	Curiosity, fluency, originality, elaboration, flexibility, divergents, messiness/risk taking
	Metacognition	Reflective, aware of thinking, strenghts and style, using metacognition

METHODS

This study used a mixed method, with an explanatory sequential design (Creswell, 2014). The reason for choosing this design is because quantitative findings are followed by qualitative findings, and both findings are strengthened by a more comprehensive explanation. Thus, this study expects the study outcomes of deep understanding or a more in-dept understanding of quantitative data.

This research utilized the quantitative method with a descriptive survey. A total of 168 (14 men and 154 women) from 195 PBTs participated in filling out the questionnaire. The goodness level of the research participants was in 2.82 %. The questionnaire consisted 24 statements of aspects of critical thinking, problem solving, creativity, metacognition of the 21st century skill (Greenstein, 2012). The questionnaire has a rating scale of 1-4, and the four levels were broadly described in Table 2.

Table 2. Rubric terminology of 21st century skill

Level 4	Level 3	Level 2	Level 1
Top tier = 3.6 to 4.0	skilled tier = 3.2 to 3.5	able tier = 2.8 to 3.1	emerging tier = 2.0 to 2.7
Exemplary	Accomplished	Developing	Beginning
Advanced	Proficient	Basic	Novice
Excellent	Good	Fair	Poor
goes beyond requirements	meets requirements	some misconception	serious error
fully complete	mostly complete	Partial	incomplete

Commented [U4]: Please use effective paragraph sentences, too many repetitions of words and sentences that refer to the same reference.

To determine the validity of the instrument used the CFA Test. This test is often used to determine the quality of instruments and is considered a credible way by previous researchers such as Suhr (2018); Chai, Deng, Tsai, and Koh (2015); Jia, Oh, Sibuma, LaBanca, and Lorentson (2016); and Sang, Liang, Chai, Dong, and Tsai (2018). The Cronbach Alpha test was used to determine the reliability of the instrument. To determine the PBT's thinking skill profile in the form of average values and standard deviations, raw data were analyzed with descriptive statistics. PBT skill levels are displayed as a percentage. Anova test was used to determine differences in male and female PBTs thinking skills. And, the correlation test is used to determine the relationship between gender and thinking factors.

In the qualitative test, in-depth interviews were conducted with 5 male PBTs and 7 female PBTs. Interviews were conducted separately between one respondent and another respondent. Interview questions given to respondents were developed according to the questionnaire indicators in the quantitative test. Triangulation was conducted on the results of the interview. Steps such as verification, display and conclusion drawing from data are carried out to obtain or justify more valid and reliable information.

RESULTS AND DISCUSSION

CFA and Alpha Cronbach Test Results

The CFA test result showed in Figure 1 (standard solution) and Figure 2 (T-value). The CFA test results showed that the *Chi Square score* = 2.69, *df* = 2, *P-value* = 0.26087 and *RMSEA* = 0.045. The reliability test results show that the *Cronbach's Alpha score* = 0.844 with *N of Items* = 24. Based on the pictures it can be concluded that all of the items (24 items) presented are valid because based on the image at the *T-Value* position there is no arrow from each indicator that was coloured Red. This finding indicates that all items are valid. In addition, the results on the *p-value* of each item indicate that for all items the *p-value* is smaller than α divided by the number of items. The results of the *p-value* are all items smaller than α divided by the number of items, it can be concluded that all items measuring each indicator of thinking are valid.

Furthermore, in the fig. 1 Standardized Solution found only one item or factor load whose number is less than 0.3. This finding indicates that points 2 to 24 can be said to be valid. Thus, the validity coefficient can be considered satisfactory if it exceeds the 0.1 (Suhr, 2018). Furthermore, Suhr (2018) stated that CFA is a picture of simplification of interrelated steps and the number of constructs and factor structures to determine the content or meaning of these factors. In addition, the findings of this study are also in line with studies conducted by Jia, Oh, Sibuma, LaBanca, & Lorentson (2016). Regarding the use of Cronbach's alpha as a reliability test, Taber (2017) has said that (a) Cronbach's alpha is a statistic used by the author to show that tests and scales that have been built or adopted for research projects, and (b) high alpha values provide limited evidence of the reliability of research instruments

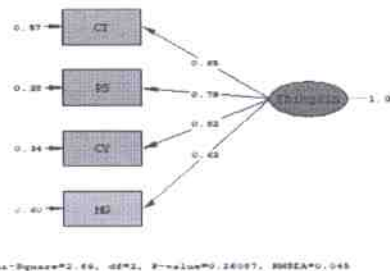

Figure 1. Conformatory factor analysis for critical thinking, problem solving, creativity, metacognition for Standardized Solution

Commented [U5]: No need to show the figure. Directly go to the results and discussion.

Commented [U6]: Please improve the picture quality

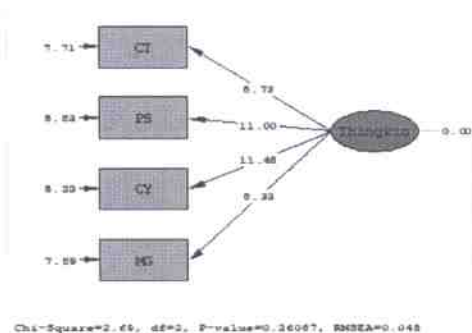

Figure 2. Conformatory factor analysis for critical thinking, problem solving, creativity, metacognition for T-Value

Profile of Thinking Skill PBTs

Table 3. Descriptive Statistics for The Profile of PBTs Thinking Skills

Thinking Skill	PBTs Skill Level (%)							
	Novice		Basic		Proficient		Exemplary	
	Male	Female	Male	Female	Male	Female	Male	Female
Critical thinking	0.11	0.09	0.16	0.16	0.33	0.21	0.40	0.44
Problem solving	0.07	0.06	0.25	0.30	0.38	0.34	0.24	0.23
Creativity	0.09	0.09	0.29	0.35	0.33	0.28	0.29	0.20
Metacognition	0.12	0.17	0.23	0.25	0.27	0.28	0.40	0.34
Total	0.39	0.41	0.93	1.06	1.31	1.11	1.33	1.21
Average	0.098	0.103	0.233	0.265	0.328	0.278	0.333	0.303
SD	0.022	0.047	0.054	0.081	0.045	0.053	0.081	0.11

Table 3 showed that the highest score for critical thinking was found at the exemplary level. The highest critical thinking score for male PBTs was 0.40%, and the highest critical thinking score for female PBTs was 0.44%. Then, the lowest critical thinking score was found at the novice level. The lowest critical thinking score for male PBTs was 0.11%, and the lowest critical thinking score for female PBTs was 0.09%.

The highest score for critical thinking was found at the exemplary level. The highest critical thinking score for male PBTs was 0.40%, and the highest critical thinking score for female PBTs was 0.44%. The lowest critical thinking score was found at the novice level. The lowest critical thinking score for male PBTs was 0.11%, and the lowest critical thinking score for female PBTs was 0.09%.

In contrast to critical thinking, the highest score for problem solving was found at a proficient level. The highest problem solving score for male PBTs was 0.38%, and the highest problem solving score for female PBTs was 0.34%. The lowest score for problem solving was found at the novice level. The lowest problem solving score for male PBTs was 0.07%, and the lowest problem solving score for female PBTs was 0.06%.

The study findings on creativity differ from both critical thinking and problem solving. The highest score for creativity skills was found at different skill levels. The highest creativity score for male PBTs was 0.33%, which was found at the professional level. The highest creativity score for female PBTs was 0.35%, which is found at the basic level. The lowest creativity score was found at the novice level. The lowest creativity score for prospective male and female PBTs was 0.09.

Similar to critical thinking, the highest score for metacognition was found at the exemplary level. The highest metacognition score for male PBTs was 0.40%, and the highest metacognition score for female PBTs was 0.34%. The

Commented [U7]: Please improve the picture quality

lowest score for metacognition was found at the novice level. The lowest metacognition score for male PBTs was 0.12%. The lowest metacognition score for female PBTs was 0.17%.

The results of this study indicate that novice was the lowest skill level for the four types of skills e.g. critical thinking, problem solving, creativity, and metacognition. The highest level for critical thinking and metacognition was found in exemplaries, and the highest level for problem solving and creativity was found in proficient, although the highest score of creativity for female biology teacher candidates was found at the basic level.

Interview results are similar to the results of descriptive statistical tests. PBTs answer questions that indicate that their critical thinking and metacognition skills are at a good level. The transcript of interviews with PBTs about the application of critical thinking skills in the learning process wrote in the following section.

1. *Researcher: In the aspect of applying critical thinking to the learning process, do you have a good understanding of the theories and facts related to the learning material?*
PTBs: I have a poor understanding of facts, principles and everything needed to help me understand the problem in learning
2. *Researcher: In the aspect of using analysis in the learning process, do you use it? How do you apply the analysis in the learning process?*
PTBs: With help, I can understand the problem directly and draw simple conclusions after being helped by others, especially by classmates. Sometimes I explain the main problems inaccurately. But I cannot contemplate it carefully in an objective way

The transcript of interviews with PBTs about the application of metacognition skills in the learning process wrote in the following section.

1. *Researcher: How do you reflect on your thinking in learning?*
PTBs: I need a visual or verbal structure to help me reflect on thoughts or with the help of others, I can improve thought reflection
2. *Researcher: Do you use metacognitive when studying? How do you do it?*
PTBs: I use my metacognitive abilities to improve my learning and productivity. I routinely apply it in daily practice

Also, PBTs answer questions that indicate that their problem solving and creativity skills are at a less or enough level. The transcript of interviews with PBTs about the application of problem solving skills in the learning process wrote in the following section.

1. *Researcher: Do you use analysis and synthesis in the learning process?*
PTBs: With the help of others, I can understand the problem directly and draw simple conclusions. But sometimes I explain the main problems inaccurately. But I cannot contemplate it carefully in an objective way. So as to combine and connect difficult ideas. So, I am less able to compile two different ideas, see a direct pattern, and summarize it
2. *Researcher: In the aspect of using evaluation in the learning process, do you have the ability to evaluate learning material?*
PTBs: The ability to evaluate objects, settings or performance that I have is quite clear, especially related to the criteria or standards given by the lecturer in learning, so that I can use and understand the evaluation process accurately

The transcript of interviews with PBTs about the application of creativity skills in the learning process wrote in the following section.

1. *Researcher: How do you elaborate and focus creativity while learning?*
PTBs: Maybe some ideas come to me if I'm really working hard and usually I can find a way to make it better. I can do one or two but my idea is relatively simple. I can do two or three things with the process: merge, modify, adjust, or rearrange
2. *Researcher: Do you study and work when you do it with flexible creativity?*
PTBs: Sometimes it's hard for me to adjust to change. When someone reminds me to think differently, I can usually do it. So that I cannot work effectively even when things change and pay attention to the potential of some things when I study

The difference in the thinking skills of male and female PBTs

Anova has been conducted to differentiate thinking skills between male and female PBTs. Before, a homogeneity test was also carried out, and the results of the test of homogeneity of variances showed that the *Levene Statistics score* = .904, *df1* = 1; *df2* = 670 and *Sig.* = .342. So it was concluded that found the similarity of variance and ANOVA test can be done. Anova test results showed on Table 4, that there are significant differences thinking skills of male and female PBTs (*F score*; 7157, *p* > 0.05). So, it was concluded that there were differences in thinking of male and female PBTs at Islamic universities.

Table 4. Anova Scores for Different of Thinking skills PBTs

	Sum of Squares	df	Mean Square	F	Sig.
Between Groups	1505.194	1	1505.194	7.157	.008
Within Groups	140911.179	670	210.315		
Total	142416.373	671			

Furthermore, correlation tests carried out to determine the relationship and interaction between gender variables (male and female) with the type of thinking (critical thinking, problem solving, creativity, and metacognition). The correlation test data for gender variables with thinking factors showed on Table 5.

Table 5. Correlation for Gender and Factor of Thinking Skill

Source	Type III Sum of Squares	Df	Mean Square	F	Sig.
Corrected Model	18011.475 ^a	7	2573.068	13.734	.000
Intercept	1028200.944	1	1028200.944	5487.930	.000
JK	1505.194	1	1505.194	8.034	.005
Indicator	1872.895	3	624.298	3.332	.019
JK * Indicator	1105.865	3	368.622	1.967	.118
Error	124404.898	664	187.357		
Total	3296276.283	672			
Corrected Total	142416.373	671			

a. R Squared = .126 (Adjusted R Squared = .117)

The results of the study showed that there is no relationship between gender with the thinking skills factor. Because, the finding indicated that (a) There was a difference in the thinking skills of male and female PBTs ($F=8.034$, $P>0.05$); (b) There was differences in the ability of PBTs based on indicators ($F=3.332$, with a significance of 0.019), and (c) There was no interaction of Gender with factors ($F=1.967$, with a significance of 0.118).

This study was found that there was no relationship between gender and PBT skills. The findings of this study were coherent with research conducted by previous researchers in biology learning. Hadjichambis, Georgiou, Hadjichambi, Kyza, & Mappouras (2016) was found that gender is only a factor that will function as a mediator in learning about human reproduction. Furthermore, in the study of toxic and non-toxic plants, no differences were found in the identification skills of poisonous plants with regard to age and sex (Prokop & Fančovičová, 2019). Špernjak & Šorgo (2018) have researched about testing differences in the knowledge gained and students' preferences for various technologies in biology laboratory work, and the results of this study showed that there were no statistical differences related to the acquisition of student knowledge between these laboratory technologies with respect to grades, gender or school score. And there are other factors that determine learning outcomes, namely the level of education in learning biology (Fonseca, Costa, Lencastre & Tavares, 2012).

The study results showed that PBTs gave their opinion that the need to increase mastery in problem solving and creativity skills. On the other hand, for critical thinking and metacognition skills, PBTs gave the opinion that they already have good skills. This finding means that the applied integrative learning has not yet had an impact or has not targeted problem solving and creativity skills for PBTs. On the other hand, integrative learning has targeted critical thinking and metaconition skills.

In this study, problem solving and creativity were less mastered competencies but it is important to be taught to prospective biology teacher students. Both of these skills involve the process of (a) describing problems with depth and clarity, (b) looking at problems with an open mind, evaluating alternatives, and considering various perspectives, (c) gathering information to make informed choices and developing plans, (d) applying and monitor with integrity and (e) evaluate the results and be willing to review the problem (Greenstein, 2012). Furthermore, this study also shows that students' problem solving skills increase when applying problem-based learning (PBL).

In this study, there are four skills that reviewed and consulted with the PBTs. The findings of this study was in line with the results of studies conducted by (Sugandi, 2018). The study results showed that there are four competencies in The Indonesian Partnership 21st Century Skills (IP-21CS) for prospective science teacher students, namely (1) 4Cs (critical thinking, creative thinking, collaboration and communication); (2) ICTs (technology, media and information literacy); (3) spiritual values (religious beliefs and spiritual awareness); and (4) charactel building (teachers' attitude and scientific attitudes).

CONCLUSION

The findings in this study indicated that: (a) the majority of male and female PBTs at Islamic universities have high skills in critical thinking and metacognition; (b) Most male and female PBTs at Islamic universities have insufficient skills in problem solving and creativity skills; (c) The results of this study show that there is no relationship between gender and PBT skills.

The results of this study can be used as criticism for educational management majors in biology education in Indonesia, especially at Islamic Universities. Educational managers need to pay attention that the application of integrative learning needs to pay attention to the skills required by PBTs. For this reason, learning applied in classrooms must be based on 21st century skills.

ACKNOWLEDGEMENTS

This work was supported by IAIN Batusangkar (grant numbers B-870.a/In.27/R.IV/TL.00/04/2019).

REFERENCES

- Afandi, A., Sajidan, S., Akhyar, M., & Suryani, N. (2019). Development Frameworks of the Indonesian Partnership 21st-Century Skills Standards for Prospective Science Teachers: A Delphi Study. *Jurnal Pendidikan IPA Indonesia*, 8(1), 89-100. <https://doi.org/10.15294/jpii.v8i1.11647>.
- Agyei, D. D., & Voogt, J. M. (2015). Pre-service teachers' TPACK competencies for spreadsheet integration: insights from a mathematics-specific instructional technology course. *Technology, Pedagogy and Education*, 24(5), 605-625. <https://doi.org/10.1080/1475939x.2015.1096822>.
- Ai, X. (1999). Creativity and academic achievement: an investigation of gender differences. *Creativity Research Journal*, 12(4), 329-337. https://doi.org/10.1207/s15326934crj1204_11.
- Alfarhan, U.F., & Dauletova, V. (2019). Revisiting the gender academic achievement gap: evidence from a unique environment. *Gender and Education*, 31(7), 827-848. <https://doi.org/10.1080/09540253.2017.1324129>.
- Argaw, A. S., Haile, B. B., Ayalew, B. T., & Kuma, S. G. (2017). The effect of problem based learning (pbl) instruction on students' motivation and problem solving skills of physics. *Eurasia Journal of Mathematics Science and Technology*, 13(3), 857-871. <https://doi.org/10.12973/eurasia.2017.00647a>.
- Aslan, A., & Zhu, C. (2017). Investigating variables predicting Turkish pre-service teachers' integration of ICT into teaching practices. *Br J Educ Technol*, 48: 552-570. <https://doi.org/10.1111/bjet.12437>.
- Bahri, A., & Corebima, A. D. (2015). The contribution of learning motivation and metacognitive skill on cognitive learning outcome of students within different learning strategies. *Journal of Baltic Science Education*, 14(4), 487-500. <http://journals.indexcopernicus.com/abstract.php?icid=1169904>.
- Bakır, S., & Öztekin, E. (2014). Creative thinking levels of preservice science teachers in terms of different variables. *Journal of Baltic Science Education*, 13(2), 231-242. <http://journals.indexcopernicus.com/abstract.php?icid=1101950>.
- Bélanger, R. E., Akre, C., Berchtold, A., & Michaud, P. A. (2011). A U-shaped association between intensity of Internet use and adolescent health. *Pediatrics*, 127(2), 330-335. <https://pediatrics.aappublications.org/content/pediatrics/127/2/e330.full.pdf>.
- Chai, C. S., Deng, F., Tsai, P. S., & Koh, J. H. (2015). Assessing multidimensional students' perceptions of twenty-first century learning practices. *Asia Pacific Education Review*, 16(3), 389-398. <https://doi.org/10.1007/s12564-015-9379-4>.
- Chang, P. S., Lee, S. H., & Wen, M. L. (2020). Metacognitive inquiry activities for instructing the central dogma concept: 'button code' and 'beaded bracelet making'. *Journal of Biological Education*, 54(1), 47-62. <https://doi.org/10.1080/00219266.2018.1546756>.
- Creswell, J. W. (2014). *Research Design: Quantitative, Qualitative and Mixed Method Approaches* (4th ed.). California: SAGE Publication, Inc.
- Damar, S. Y., Özdemir, Ö. F., & Unal, C. (2015). Pre-service physics teachers' metacognitive knowledge about their instructional practices. *Eurasia Journal of Mathematics, Science & Technology Education*, 11(5), 1009-1026. <https://doi.org/10.12973/eurasia.2015.1370a>.
- Drake, S. M., & Reid, J.L. (2018). Integrated curriculum as an effective way to teach 21st century capabilities. *Asia Pacific Journal of Educational Research*, 1(1), 31-50. https://www.researchgate.net/publication/324250557_Integrated_Curriculum_as_an_Effective_Way_to_Teach_21st_Century_Capabilities.

Commented [U8]: 1. Please provide at least 30 references which 80% of them are taken from the last 10 years (>2010) articles of no-predatory journals, written in accordance with the APA Standard. You may go to Google Scholar and find the right format for APA Style provided.

2. For books, please refer to the original/primary book reference no matter the date.

3. All of the listed references must be cited in the body of the article, and vice versa.

Commented [U9]: use the references from the last 10 years (>2010)

Commented [U10]: Cannot be found in the body of article

- Duran, M., & Dökme, İ. (2016). The effect of the inquiry-based learning approach on student's critical-thinking skills. *Eurasia Journal of Mathematics, Science & Technology Education*, 12(12), 2887-2908. <https://doi.org/10.12973/eurasia.2016.02311a>.
- Elder, L. (2007). Another brief conceptualization of critical thinking. <http://www.criticalthinking.org/pages/defining-critical-thinking/766>.
- Fitriani, H., Asy'ari, M., Zubaidah, S., & Mahanal, S. (2019). Exploring the prospective teachers' critical thinking and critical analysis skills. *Jurnal Pendidikan IPA Indonesia*, 8(3), 379-390. <https://doi.org/10.15294/jpii.v8i3.19434>.
- Fonseca, M. J., Costa, P., Lencastre, L., & Tavares, F. (2012). Multidimensional analysis of high-school students' perceptions about biotechnology. *Journal of Biological Education*, 46(3), 129-139. <https://doi.org/10.1080/00219266.2011.634019>.
- Geisinger, K. F. (2016). 21st century skills: What are they and how do we assess them? *Applied Measurement in Education*, 29(4), 245-249. <http://dx.doi.org/10.1080/08957347.2016.1209207>.
- Greenstein, L. (2012). *Assessing 21st century skill, a guide to evaluating mastery and authentic learning*. California: SAGE Company. <https://eric.ed.gov/?id=ED534306>.
- Greiff, S., & Kyllonen, P. (2016). Contemporary assessment challenges: the measurement of 21st century skills. *Applied Measurement in Education*, 29(4), 243-244. <https://doi.org/10.1080/08957347.2016.1209209>.
- Hadjichambis, A. Ch., Georgiou, Y., Hadjichambi, D. P., Kyza, E. A., & Mappouras, D. (2016). Investigating the effectiveness of an inquiry-based intervention on human reproduction in relation to students' gender, prior knowledge and motivation for learning in biology. *Journal of Biological Education*, 50(3), 261-274. <https://doi.org/10.1080/00219266.2015.1067241>.
- Haviz, M. (2016). Designing and developing the integrated learning model on embryology. *Transylvanian Review*, 24(7). <http://transylvanianreviewjournal.org/index.php/TR/article/view/2998>.
- Haviz, M., Karomah, H., Delfita, R., Umar, M. I. A., & Maris, I. M. (2018). Revisiting generic science skills as 21st century skills on biology learning. *Jurnal Pendidikan IPA Indonesia*, 7(3), 355-363. <https://journal.unnes.ac.id/nju/index.php/jpii/article/view/12438>.
- Haviz, M., Lufri, Fauzan, A., & Efendi, Z. M. (2012). Pengembangan model pembelajaran integratif pada biologi perkembangan hewan: analisis kebutuhan pengembangan. *Ta'dib*, 15(1), 1-14. <http://ecampus.iainbatuangsar.ac.id/ojs/index.php/takdib/article/viewFile/213/212>.
- Holland, D. D., & Piper, R. T. (2014). A technology integration education (TIE) model: Millennial preservice teachers' motivations about technological, pedagogical, and content knowledge (TPACK) competencies. *Journal of Educational Computing Research*, 51(3), 257-294. <https://doi.org/10.2190/ec.51.3.a>.
- Jia, Y., Oh, Y. J., Sibuma, B., LaBanca, F., & Lorentson, M. (2016). Measuring twenty-first century skills: development and validation of a scale for in-service and pre-service teachers. *Teacher Development: An International Journal of Teachers' Professional Development*, 20(2), 229-252. <http://dx.doi.org/10.1080/13664530.2016.1143870>.
- Kan'an, A. (2018). The relationship between Jordanian students' 21st century skills (Cs21) and academic achievement in science. *Journal of Turkish Science Education*, 15(2), 82-94. <https://doi.org/10.12973/tused.10232a>.
- Larson, L. C., & Miller, T. N. (2011). 21st century skills: Prepare students for the future. *Kappa Delta Pi Record*, 47(3), 121-123. <http://dx.doi.org/10.1080/00228958.2011.10516575>.
- Listiana, L., Susilo, H., Suwono, H., & Suarsini, E. (2016). Empowering students' metacognitive skills through new teaching strategy (group investigation integrated with think talk write) in biology classroom. *Journal of Baltic Science Education*, 15(3), 391-400. <http://journals.indexcopernicus.com/abstract.php?icid=1211248>.
- Lucas, B. (2016). A five-dimensional model of creativity and its assessment in schools. *Applied Measurement in Education*, 29(4), 278-290. <http://dx.doi.org/10.1080/08957347.2016.120920>.
- Maryuningsih, Y., Hidayat, T., Riandi, R., & Rustaman, N. (2019). Critical thinking skills of prospective biology teacher on the chromosomal basic of inheritance learning through online discussion forums. *J. Phys.: Conf. Ser.* 1157 022090. <https://doi.org/10.1088/1742-6596/1157/2/022090>.
- Nawani, J., Kotzebue, L. V., Spangler, M., & Neuhaus, B. J. (2019). Engaging students in constructing scientific explanations in biology classrooms: a lesson-design model. *Journal of Biological Education*, 53(4), 378-389. <https://doi.org/10.1080/00219266.2018.1472131>.
- Pedersen, J. M. (2019). Gender achievement gaps: Reexamining the transformational debate. *Childhood Education*, 95(5), 74-78. <https://doi.org/10.1080/00094056.2019.1663109>.
- Prokop, P. & Faňčovičová, J. (2019). The perception of toxic and non-toxic plants by children and adolescents with regard to gender: implications for teaching botany. *Journal of Biological Education*, 53(4), 463-473. <https://doi.org/10.1080/00219266.2018.1501405>.

- Reese, H.W., Lee, L.J., Cohen, S. H., & Puckett Jr, J. M. (2001). Effects of intellectual variables, age, and gender on divergent thinking in adulthood. *International Journal of Behavioral Development*, 25(6), 491-500. <https://doi.org/10.1080/01650250042000483>
- Rejskind, F.G., Rapagna, S. O., & Gold, G. (1992). Gender differences in children's divergent thinking. *Creativity Research Journal*, 5(2), 165-174. <https://doi.org/10.1080/10400419209534430>.
- Sang, G., Liang, J. C., Chai, C. S., Dong, Y., & Tsai, C. C. (2018). Teachers' actual and preferred perceptions of twenty-first century learning competencies: a Chinese perspective. *Asia Pacific Education Review*, 19(3), 307-317. <https://doi.org/10.1007/s12564-018-9522-0>.
- Sladek, R.M., Bond, M.J., &Phillips, P.A. (2010). Age and gender differences in preferences for rational and experiential thinking. *Personality and Individual Differences*, 49(8), 907-911. <https://doi.org/10.1016/j.paid.2010.07.028>.
- Sondergeld, T. A., &Johnson, C. C. (2019). Development and validation of a 21st Century Skills Assessment: Using an iterative multimethod approach. *School Science and Mathematics*, 119, 312– 326. <https://doi.org/10.1111/ssm.12355>.
- Špernjak, S., &Šorgo, A. (2018). Differences in acquired knowledge and attitudes achieved with traditional, computer-supported and virtual laboratory biology laboratory exercises. *Journal of Biological Education*, 52(2), 206-220. <https://doi.org/10.1080/00219266.2017.1298532>.
- Suhr, D. D. (2018). *Exploratory or Confirmatory Factor Analysis?* <http://www2.sas.com/proceedings/sugi31/200-31.pdf>.
- Taber, K. S. (2017). The use of Cronbach's alpha when developing and reporting research instrumen in science education. *Res. Sci. Educ.* <http://dx.doi.org/10.1007/s11165-016-9602-2>.
- Teo, P. (2019). Teaching for the 21st century: A case for dialogic pedagogy. *Learning, Culture and Social Interaction*, 21, 170-178. <https://doi.org/10.1016/j.lcsi.2019.03.009>.
- Wang, Y., Lavonen, J., & Tirri, K. (2018). Aims for learning 21st century competencies in national primary science curricula in china and finland. *Eurasia Journal of Mathematics, Science and Technology Education*, 14(6), 2081 -2095. <https://doi.org/10.29333/ejmste/86363>.
- Warren, F., Apps, E. M., Hoskins, S., Azmi, Z., & Boyce, J. (2018). The role of implicit theories, age, and gender in the creative performance of children and adults. *Thinking Skills and Creativity*, 28, 98-109. <https://doi.org/10.1016/j.tsc.2018.03.010>.
- Wartono, W., Hudha, M. N., &Batlolona, J. R. (2018). How are the physics critical thinking skills of the students taught by using inquiry-discovery through empirical and theoretical overview? *Eurasia Journal of Mathematics Science and Technology*, 14(2), 691-697. <https://doi.org/10.12973/ejmste/80632>.
- Zainuddin, Z., &Perera, C. J. (2017). Exploring students' competence, autonomy and relatedness in the flipped classroom pedagogical model. *Journal of Further and Higher Education*, 43(1), 115-126. <http://dx.doi.org/10.1080/0309877X.2017.1356916>.
- Zainuddin, Z., &Attaran, M. (2015). Malaysian students' perceptions of flipped classroom: A case study. *Innovations in Education and Teaching International* 53(6): 660–670. <https://doi.org/10.1080/14703297.2015.1102079>.